



Consultant - Audit - Engineering

IN COMMERCIAL REFRIGERATION SYSTEMS

(hypermarkets, supermarkets, ...)



Measurements

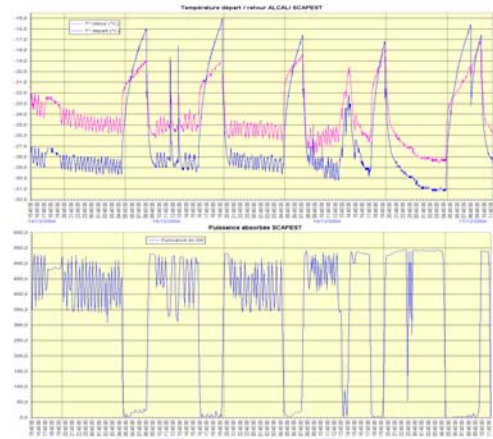

Energy audits

COMPETENCES

Optimizations :

- Refrigerating,
- Energetic,
- Environmental.

Specific fluids :

- Ammonia,
- CO₂,
- Diphasic brine,
- Monophasic brine.

Formations.

Regulations and standardizations.

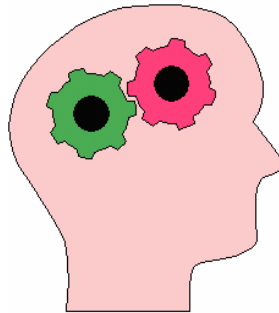

MISSIONS

- Feasibility studies.
- Project studies.
- Follow-up of construction.
- Measurement series.
- Technical audits.
- Energy audits.
- Assistances.

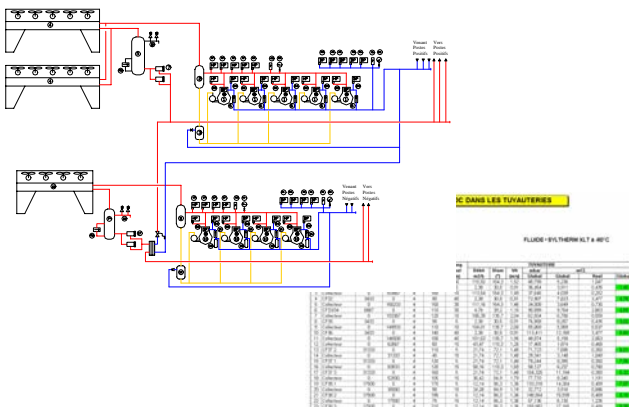

Designs



Follow-up of projects

Assistance Développement Technique

57, rue Eugène Caron - 92400 Courbevoie - France
Tél. : +33.(0)1.69.51.78.24 - Fax : +33.(0)1.69.51.24.45

www.adtplus.net
contacts@adtplus.net